

# Wilkhahn

Chassis. 340 range.





Chassis.

Innovative.

Multipurpose.

Appealing.

Virtually no other chair has caused more of a stir in the design world than multipurpose chair Chassis. And it's no surprise. Because the distinctive and ground-breaking design of the frame, consisting of deep-drawn sheet steel, indicates a highly innovative manufacturing process called space frame technology from the automotive industry. This technology combines elastic comfort, durability and strength with the precision and elegance of a fascinating design. The combination of a variety of unitary, membrane-like seat- and backrest-shells produces models that set any design concept apart. Available in monochrome versions with through-dyed plastic shells, or covered with robust, informal or elegant fabrics, or perhaps with slim-line upholstery and covered with leather, Chassis is a trendsetting statement in any backdrop. It's an ideal choice for meeting rooms, recreational areas, workshops and studios, customer service areas, hotel rooms, restaurants or conferences. Quite simply, it's a chair for contemporary life styles.

Design: Stefan Diez



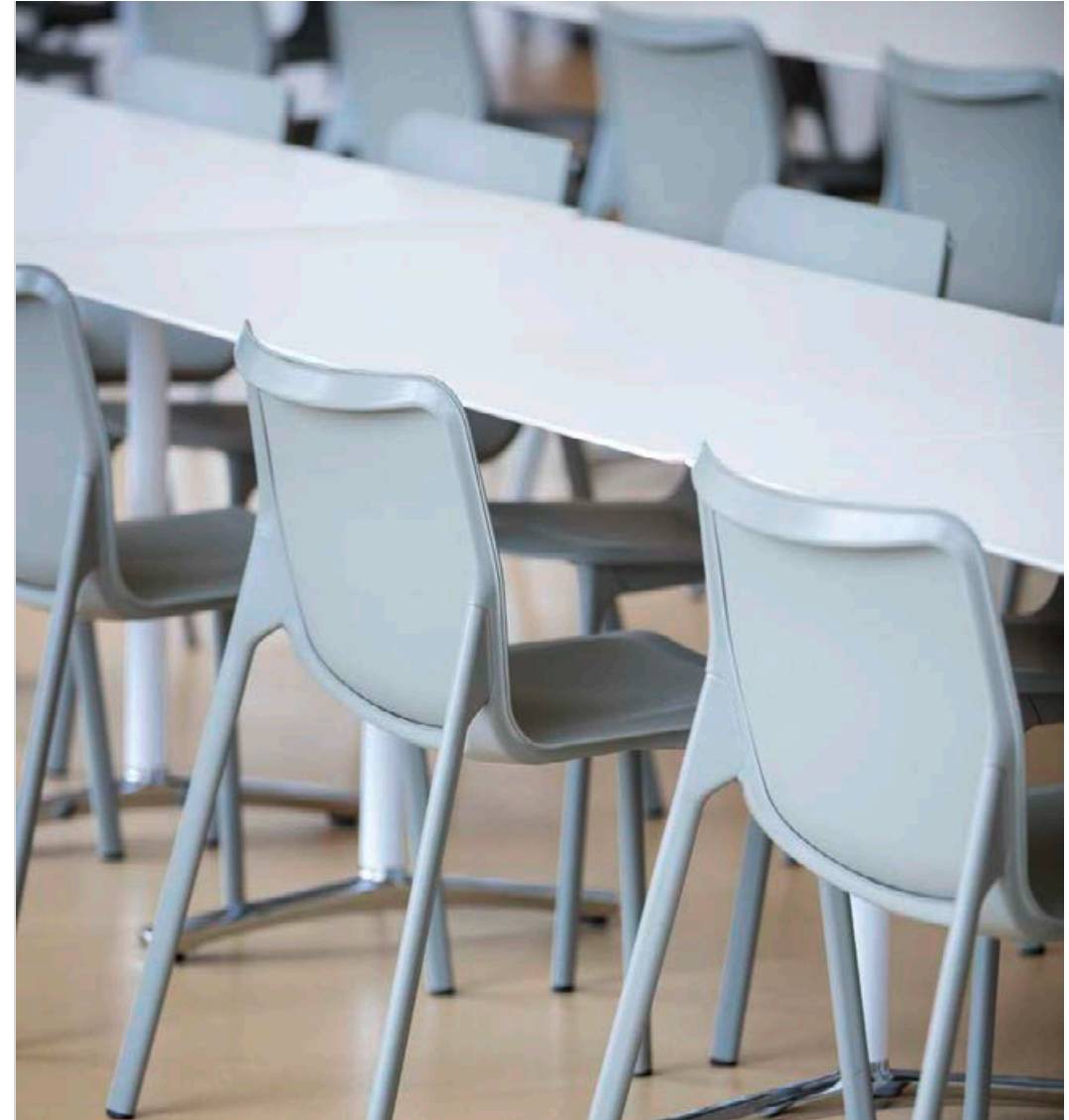
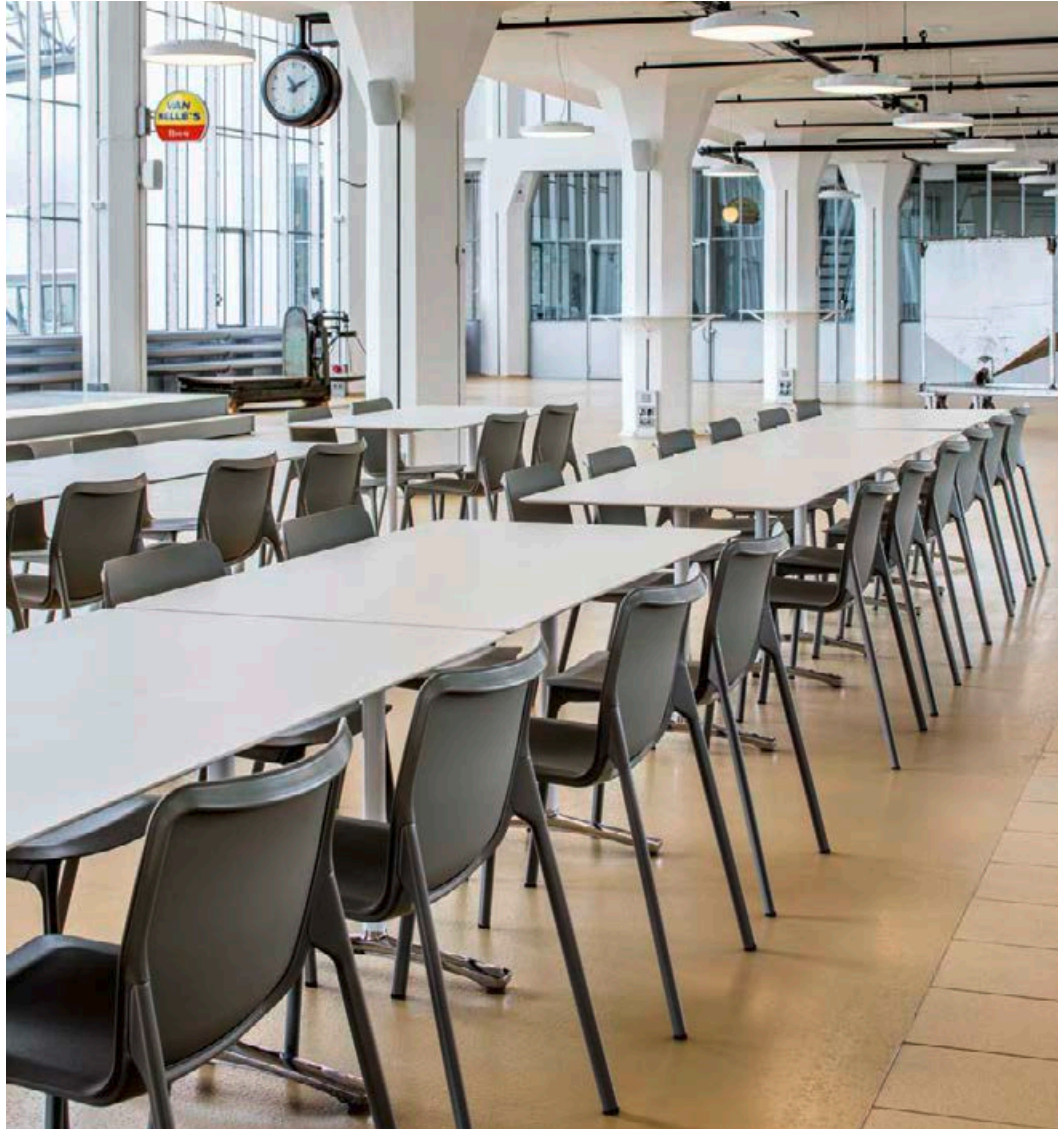

# Chassis. 340 range. Technical details.

# Wilkhahn

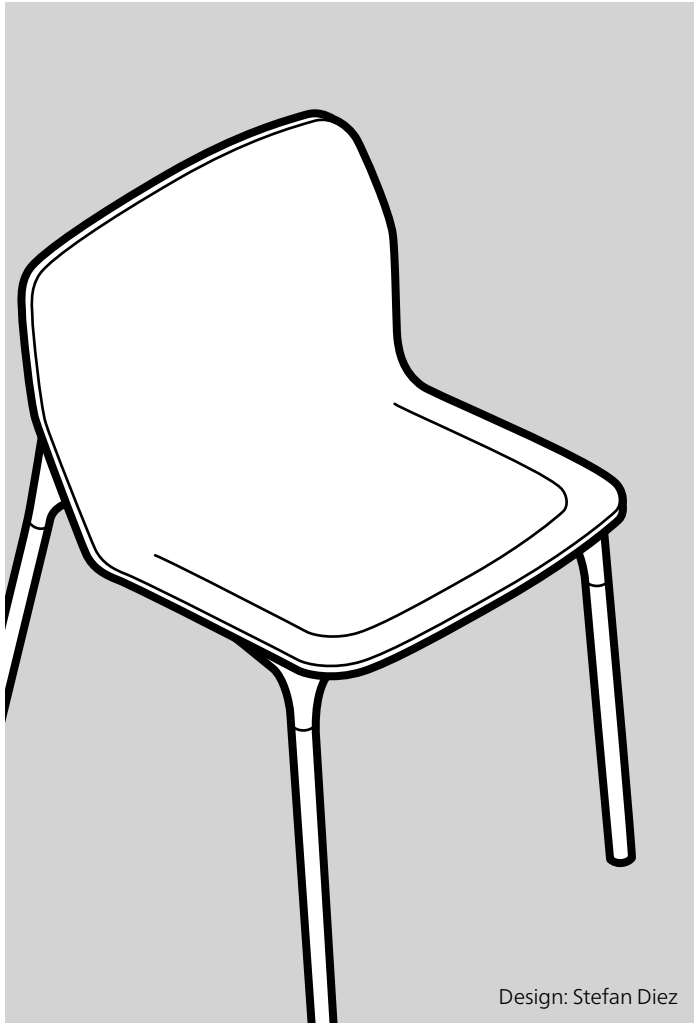

### Function

Four-leg, lightweight multipurpose chair for meeting rooms, informal meeting spaces, cafeterias, show-rooms, customer service areas, hotels or dining rooms.

### Frame

Frame made of three-dimensional, deep-drawn, extremely strong sheet steel, coated in graphite black, concrete-grey, grey-white, signal white, fire red or brown-green. Black plastic multipurpose glides for all types of flooring. Model 341/7 (outdoor variant) with extra coating to protect from corrosion. Only in combination with a black coated frame and black shell.

### Seat and backrest

Unitary seat and backrest shell made of finely grained plastic (model 341/1) or with a textile cover (model 341/5) or fully upholstered with cut foam, covered in leather, rear of shell covered in leather (model 341/6).

### Standards

The Chassis multipurpose chairs comply with the DIN EN 13761 standard.



www.tuv.com  
ID 1000000000

# Chassis. 340 range. Product types.

# Wilkhahn



**341/1** Multipurpose chair stackable 4-high free-standing, frame coated



**341/5** Multipurpose chair with textile cover, not stackable, frame coated



**341/6** Multipurpose chair leather-covered fully upholstered, not stackable, frame coated



**341/7** Outdoor multipurpose chair stackable 4-high free-standing, frame coated

## Frame colours



RAL colours graphite black, cement grey, grey white, signal white, flame red or brown-green

You can find our current fabric collection in our media center.

## Seat and backrest shells



Black, grey, white plastic

## Upholstery material

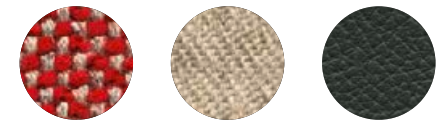

C2 | C3 | 74 | You can find all upholstery materials and more colours in our media center

The digital sample colours differ from the originals.

# Chassis. 340 range. Models and dimensions.

# Wilkhahn

**341/1**  
Multipurpose chair

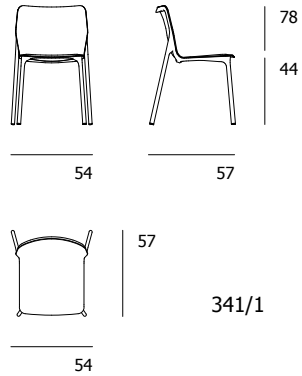

**341/1**  
Multipurpose chair

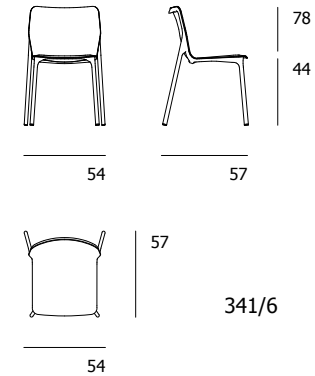
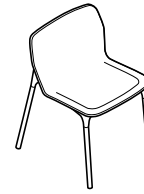

**341/5**  
Multipurpose chair

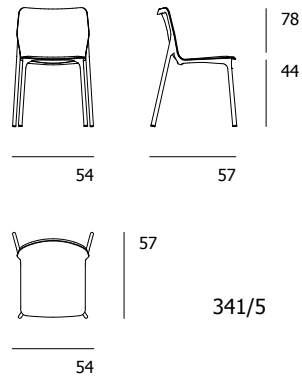
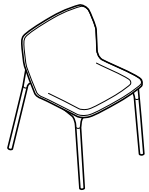

**341/5**  
Outdoor multipurpose chair

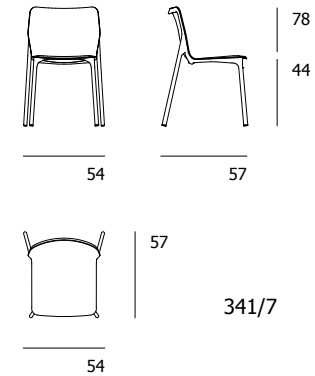

# Chassis. 340 range. Awards / standards / certificates.

# Wilkhahn

## Awards



## Product certificates / product standards



DIN EN 13761

## Company's certificates, memberships



## Environment and product

The designer's idea is the beginning of the story. Like a stylish and elegant bicycle saddle, the new chair is to combine technical stability and precision with comfort and a contoured shape. The result is a lightweight, comfortable and easy to handle four-legged chair, where the structure and the shell fuse to become a distinctive unit with a strong appeal. Lucid, but still organic, contoured but still lightweight, technically precise, but still natural.

- Thanks to the deep-drawing procedures, thin sheet metal is used as the frame's material. In this case, the strength is not produced by the thickness of the material, but by moulding it in small radii. The press uses 300 tonnes of pressure to pull the pre-cut fine sheet steel in one piece to make the seat and backrest shell. Geometry, cut-out parts, pressure, speed and damping are perfectly attuned in the process.
- The exchangeable seat and backrest shell, made of finely grained polypropylene, is also industrial design at its best. With a patented, concealed connection method it's placed, using a form-fit procedure, to the frame which is then lent even more stability.
- Just two materials are used, therefore complying with the demand for a few, pure and recyclable materials. Sheet steel is easily available and can be recycled without any loss of quality. Polypropylene can be recycled into plastic granulate.
- The lasered croppings of metal are used to produce the four connecting points, so that virtually no wastage is created. Therefore, this process is very economical on materials and saves on weight.
- The power coating is free of solvents and guarantees longlasting surface quality.
- The seat shell is easy to exchange, so that Chassis can be given a brand-new look and adapt to different backdrops.