

ON[®] Environmental Product Information.

design made in germany **Wilkhahn**



ON. The new dimension in seating.
ON range, design: wiege

Leading healthcare professionals and ergonomists have long been pleading for new ergonomic approaches. And ON turns these demands into reality. After five years in development and with Wilkhahn's four decades of expertise in dynamic seating, ON's 2009 world premiere is a unique office chair concept. A chair that gives our bodies the freedom to sit the way they want and can. At the core of the innovative concept lies Trimension®, three-dimensional synchro-supporting kinematics for the seat and back with swivel points that precisely follow the positions of and scope of movement in the knee and hip joints. Therefore, the body's centre of gravity stays in perfect balance – whatever the posture or motion involved. Prof. Ingo Froböse from the Centre for Health accompanied the project and confirms that: "This office chair stimulates a new range of natural postures and movement that activates the entire body. You could say that ON teaches seating how to walk". So ON is a new milestone for better health and enhanced performance in the office, in short: for the next generation in dynamic seating.

With just two buttons and the integrated rapid adjustment mechanism, ON is easy and convenient to adjust while you're seated. Trimension®, the 3D kinematics, is designed for people weighing from 45 to 120 kilos. The combination of two swing plates, moving independently like thighs, highly elastic seat shell and backrest design (Flexframe®), as well as the cover with its micro-cushioning effect, offer maximum potential for adjusting the chair yourself and are an assurance of comfort.

Guidelines.

Truthfulness in product design

We strive to develop lasting products, increase their utility value and reduce waste. "Less is more" or "reduce to the max" are the guiding principles that Wilkhahn continually translates into future contexts. Ecologically oriented design principles are a natural, integral part of product development.

Fairness in cooperation

We focus on people. This implies a cooperative style of management that recognizes employees' representatives as being co-managers who share in shaping the company. Profit-sharing for employees, the development of new forms of work with partly autonomous group and project work, as well as a firmly established health management scheme mark Wilkhahn's social orientation.

Ecological responsibility

Wilkhahn pursues the goal of sustainable development. Wilkhahn corporate culture is shaped by the balance that we strive to achieve between economic, ecological, social and cultural objectives for safeguarding the independence of the company. Adherence to environmentally relevant criteria throughout the entire product life cycle forms the basis of the way in which we judge our success.

Wilkhahn at a glance – commitment statements, certification, awards.

UN-Global Compact, ISO 9001/14001, EMAS, GREENGUARD™, LEED

Sustainability:



UN Global Compact

Processes:



ISO 9001
ISO 14001



EMAS

Product: ON



GREENGUARD™



Complies with the requirements for the following number of credits under LEED:
LEED CI 5 – 7
LEED NC 5
LEED EB 7

Milestones of socio-ecological development at Wilkhahn

2009 Wilkhahn signed an international framework agreement to assure and extend exemplary social standards on a global scale. Regular internal checks and external monitoring carried out by the workers union IG Metall guarantee that Wilkhahn and its suppliers meet fundamental standards of the International Labour Organization (ILO).

2008 The newly erected co-generator for combining power and heat at the Bad Münder site is powered by renewable raw materials and since 2008 it has ensured virtually CO₂-neutral production

2001 First company in Lower Saxony, Germany, to be certified in accordance with the European Environmental Standard of EMAS 2

2000 Publication of the first sustainability report in the sector of medium-sized companies: Wilkhahn Added Values

1997 Corporate Conscience Award of Council on Economic Priorities, New York

1996 German Ecology Prize of the Deutsche Bundesstiftung Umwelt

1995 Development and introduction of transport packaging; changeover in table lacquering to low-solvent, water-based lacquer

1994 Preparation and implementation of a waste management concept according to the premises of recycling management

1992 Introduction of the Picto swivel chair range as the first office chair in the world with a design concept integrating consistently ecological criteria

1989 Start of "Wilkhahn Green" with a policy statement on ecology: "The Administrative Board and Management have decided jointly to take ecological matters seriously and, in case of doubt, to give priority to such over and above quick profit"

Healthy, compact and service friendly

The new seating concept encourages a free range of motion. As a result our metabolism is enhanced which is the most important factor in our feeling of well-being. This entails a number of benefits in terms of social interaction, business and economic performance. Durability of the form, function and material are the foundations for economic and ecological sustainability. This includes the ability to retrofit additional features, a service-friendly design and modular exchangeability of the seat upholstery panel, backrest, covers and expendable parts. When developing the chair, emphasis was placed from very beginning in ensuring maximum recyclability of the materials - as far as technically possible. After the end of its life, 96% of ON can be recycled. Due to the tool-free, knock-down assembly of the backrest, the transportation volume is reduced by about 45% compared with other conventional packaging types. This allows facility management customers to keep a large space-saving range in stock (with different seat and backrests).

- The materials marry extreme precision with robust stability. The bases consist optionally of die-cast aluminium, or through-dyed, fibreglass reinforced polyamide and the swing plates of die-cast aluminium. The flexible seat shell and seat upholstery panel are made of polypropylene, the back frame and the armrests of fibreglass-reinforced polyamide, optionally with pads made of polyurethane elastomer or polyurethane foam. The mechanism housing is die-cast aluminium with a polypropylene top cover. A maximum 100% of the aluminium and polypropylene components are recyclable.
- The seat cushions are made of CFC-free covered polyurethane. In addition to the seat upholstery panel, they can also be removed, as well as the cover to the back frame of permanently elastic, breathable 3D polyester fabric.
- The adjustment and motion functions are simplicity itself and offer ease of use. Consequently, if a chair wears out, it can be easily repaired or retrofitted to extend its useful life.

The worldwide new standard in three-dimensional dynamic seating is equally straightforward and high quality. The clever reduction in the number of parts due to innovative design and the integrated multiple functions are eco-friendly and mean excellent value.

Responsibility from the very start – Wilkhahn Environmental Product Information

The environmental impact of the Logon table has been evaluated for the entire product life cycle – including the extraction of raw materials, manufacturing, utilization and waste disposal – on the basis of a life cycle analysis and assessment (LCA).

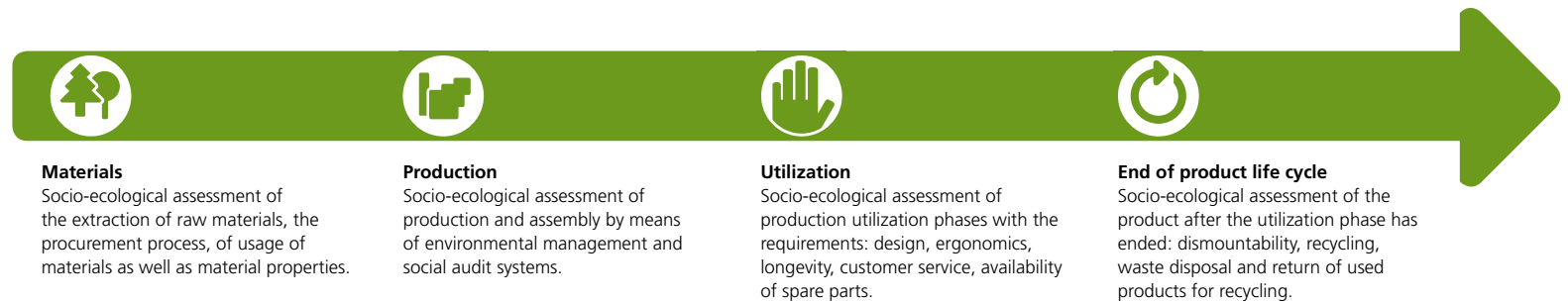

Materials

Socio-ecological assessment of the extraction of raw materials, the procurement process, of usage of materials as well as material properties.



Production

Socio-ecological assessment of production and assembly by means of environmental management and social audit systems.



Utilization

Socio-ecological assessment of production utilization phases with the requirements: design, ergonomics, longevity, customer service, availability of spare parts.



End of product life cycle

Socio-ecological assessment of the product after the utilization phase has ended: dismantability, recycling, waste disposal and return of used products for recycling.



Materials.

Material composition

	kg	in %
Metals		
Aluminium	6.17	33.1
Steel	3.12	16.1
Zinc	0.70	3.7
Plastics		
Polyamide	2.95	15.8
Polypropylene	2.59	13.9
Fibreglas	1.73	9.3
ABS plastic	0.57	3.1
Polyurethane foam	0.45	2.4
Others	0.38	2.0
Total weight	18.64	100

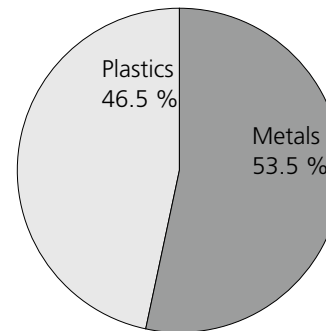

The total weight of the chair is 18.64 kg.

The ON chair comprises 55 percent recycling material (aluminium / steel / plastics).

The materials used for ON office chairs are subject to stringent control.

An ABC analysis is used to examine substances contained in these materials in terms of environmental and health compatibility. Prohibited chemicals are not used in the product at all. All manufacturing supplies are contained in a register of hazardous substances that forms a basis for further minimization or substitution in the case of potential problematic substances.



Architectural environment



Co-generator powered by renewable raw materials



Production.

Water pollution control, waste management and sustainable production of energy

Water is becoming an increasingly important resource. Wilkhahn spares no effort to minimize water consumption in production and to ensure that water quality is not impaired. Due to the treatment of process water, the quantities of waste water requiring special supervision has been reduced by 80 per cent.

The Wilkhahn waste management concept embraces sorting waste according to one-type materials, recycling and disposal of all fractions of waste resulting from production and administration.

The newly erected co-generator for combining power and heat at the Bad Münde site is powered by renewable raw materials and since 2008 onwards it ensures almost CO₂ neutral production.

Wilkhahn production sites

ON office chairs are produced and assembled in Bad Münde (Germany), Castellon (Spain) and Sydney (Australia).

Environmental management system

All Wilkhahn sites work in conformity with a uniform environmental management system that is validated at the Bad Münde site (Germany) and certified in accordance with EMAS ISO 14001.

Process safety and quality management

Both the main Wilkhahn production site and all European sales offices are certified in accordance with ISO 9001. When selecting suppliers, Wilkhahn assigns great value to a comprehensive and viable quality management system.

ILO: All Wilkhahn production facilities guarantee compliance with labour and social standards as required by the ILO (International Labour Organization). Such compliance also forms the basis of cooperation with suppliers. The ILO is primarily concerned with the formulation and implementation of international labour and social standards, particularly core work standards that ensure social and just interpretation and application of all aspects of globalization, as well as the promotion of decent work.

Employees as partners

Top performance requires a potential-oriented corporate organization with flexible working hours, a bonus scheme, and group and project work. In turn, all employees share in corporate success in material terms. They have a comprehensive pension scheme; they are at the heart of company health promotion measures and they work in an environment that, by taking groundbreaking steps in industrial architecture, strives to achieve a synthesis of social, ecological, economic and aesthetic needs.

ON[®]

Environmental Product Information.

design made in germany

Wilkhahn

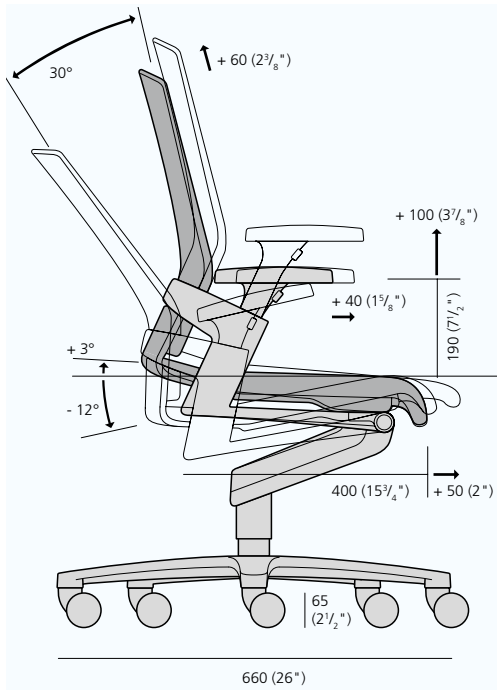

Use.

Aesthetics and design

Sustainable products must be purposive. The timeless aesthetics of the ON range result in an increase in utility value in terms of enduring use. Office work today requires maximum flexibility – in terms of interiors, utilization concepts, processes and people. The most efficient answer here is to specify a task chair that is ergonomically adjustable to every employee, and one that fits in well with any environment due its calm, understated design. Not only employees, company doctors and facility managers are delighted with ON, but designers too. It is a satisfying solution if healthy sitting can be combined with aesthetic calibre.

Longevity and guarantee

ON sets standards for product design that is "sustainable" in the most optimal way. The durability of the high-quality materials used, the innovative sitting concept and the classic design guarantee usability for many decades. We give a two-year manufacturers' guarantee which thus provides a serious planning and specifying timeframe. We can vouch for this regardless of the long product service life entailed. We regard guarantees over and above such timeframes as an investment in the future. Our service in terms of "ecological prolongation of service life" includes general overhauling and maintenance of older chairs. Wilkhahn offers repair service for furniture units no longer produced for two further years following discontinuation.

Air quality and emissions of pollutants

ON office chairs do not emit any concentrations of gas that are harmful to the environment or to health. Products from the ON range are certified in the USA in accordance with GREENGUARD Indoor Air Quality™. GREENGUARD™ is a certification programme for low emitting products.

ON[®]

Environmental Product Information.

design made in germany

Wilkhahn



End of product life cycle.

Return of used products and recycling

Our responsibility does not stop at the end of the utilization phase of a product as we offer our customers extensive services for taking back and recycling used products. We guarantee that used products may be returned in their entirety. The chairs are dismantled at our plant, all components are sorted according to one-type materials and – if possible – are recycled. Due to the clear marking and identification of all materials, due to their nontoxicity and due to easy dismantability, we can today ensure that the components of a Wilkhahn product are returned to both decentral and local material and production cycles and are properly recycled and, if necessary, disposed of. This serves to reduce energy-intensive (and thus ecologically questionable) return transport over long distances.

Disassembly and recycling

All components of the ON office chair permit non-destructive disassembly. All components weighing more than 150 g bear a material identification mark to ensure that materials can be sorted according to a single type. No material protecting agents or halogen-organic compounds are used that prevent subsequent recycling. A total of 98 percent of components of the chair can be recycled.

Returnable transport packaging

Returnable transport packaging made from renewable raw materials is used for ON office chairs that can be reused, recycled or composted.